

**General Aptitude (GA)****Q.1 – Q.5 Carry ONE mark Each**

Q.1	If '→' denotes increasing order of intensity, then the meaning of the words [dry → arid → parched] is analogous to [diet → fast → _____ ]. Which one of the given options is appropriate to fill the blank?
(A)	starve
(B)	reject
(C)	feast
(D)	deny
Q.2	If two distinct non-zero real variables $x$ and $y$ are such that $(x + y)$ is proportional to $(x - y)$ then the value of $\frac{x}{y}$
(A)	depends on $xy$
(B)	depends only on $x$ and not on $y$
(C)	depends only on $y$ and not on $x$
(D)	is a constant

Q.3	Consider the following sample of numbers:  9, 18, 11, 14, 15, 17, 10, 69, 11, 13  The median of the sample is
(A)	13.5
(B)	14
(C)	11
(D)	18.7
Q.4	The number of coins of ₹1, ₹5, and ₹10 denominations that a person has are in the ratio 5:3:13. Of the total amount, the percentage of money in ₹5 coins is
(A)	21%
(B)	$14\frac{2}{7}\%$
(C)	10%
(D)	30%

Q.5	For positive non-zero real variables $p$ and $q$ , if $\log(p^2 + q^2) = \log p + \log q + 2 \log 3,$ then, the value of $\frac{p^4 + q^4}{p^2 q^2}$ is
(A)	79
(B)	81
(C)	9
(D)	83

**Q.6 – Q.10 Carry TWO marks Each**

<p>Q.6</p>	<p>In the given text, the blanks are numbered (i)–(iv). Select the best match for all the blanks.</p> <p>Steve was advised to keep his head _____<sup>(i)</sup> before heading _____<sup>(ii)</sup> to bat; for, while he had a head _____<sup>(iii)</sup> batting, he could only do so with a cool head _____<sup>(iv)</sup> his shoulders.</p>
(A)	(i) down      (ii) down      (iii) on      (iv) for
(B)	(i) on      (ii) down      (iii) for      (iv) on
(C)	(i) down      (ii) out      (iii) for      (iv) on
(D)	(i) on      (ii) out      (iii) on      (iv) for

Q.7	<p>A rectangular paper sheet of dimensions <math>54 \text{ cm} \times 4 \text{ cm}</math> is taken. The two longer edges of the sheet are joined together to create a cylindrical tube. A cube whose surface area is equal to the area of the sheet is also taken.</p> <p>Then, the ratio of the volume of the cylindrical tube to the volume of the cube is</p>
(A)	$1/\pi$
(B)	$2/\pi$
(C)	$3/\pi$
(D)	$4/\pi$

Q.8

The pie chart presents the percentage contribution of different macronutrients to a typical 2,000 kcal diet of a person.

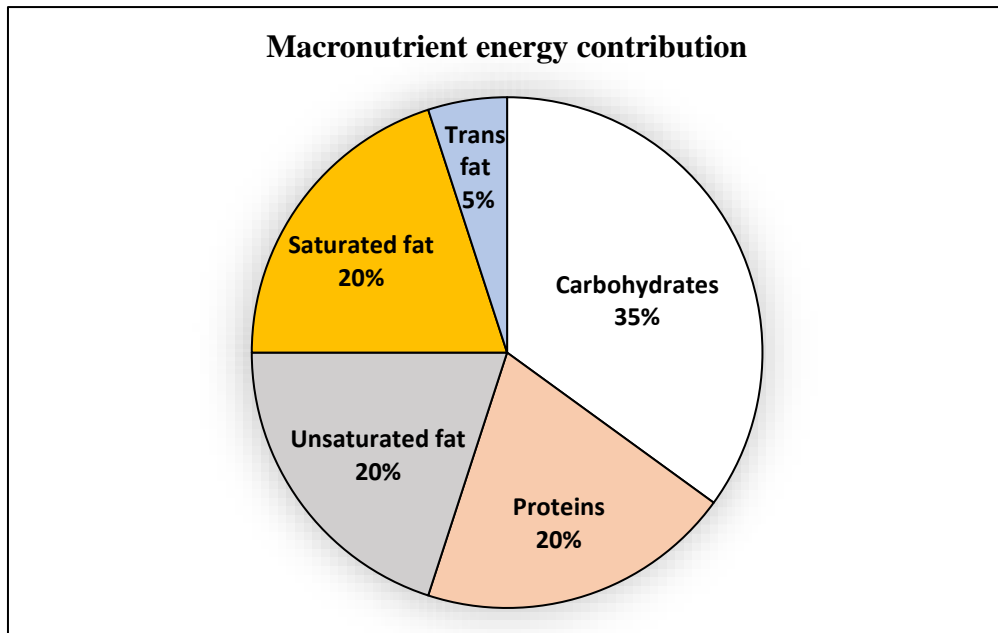

The typical energy density (kcal/g) of these macronutrients is given in the table.

Macronutrient	Energy density (kcal/g)
Carbohydrates	4
Proteins	4
Unsaturated fat	9
Saturated fat	9
Trans fat	9

The total fat (all three types), in grams, this person consumes is

- (A) 44.4
- (B) 77.8
- (C) 100
- (D) 3,600

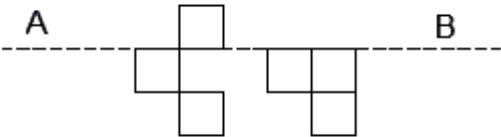
Q.9	A rectangular paper of 20 cm × 8 cm is folded 3 times. Each fold is made along the line of symmetry, which is perpendicular to its long edge. The perimeter of the final folded sheet (in cm) is
(A)	18
(B)	24
(C)	20
(D)	21
Q.10	<p>The least number of squares to be added in the figure to make AB a line of symmetry is</p> 
(A)	6
(B)	4
(C)	5
(D)	7

## Q.11 – Q.35 Carry ONE mark Each

Q.11	The following system of linear equations $7x - 3y + z = 0$ $3x - y + z = 0$ $x - y - z = 0$ has:
(A)	infinitely many solutions
(B)	a unique solution
(C)	no solution
(D)	three solutions



Q.12	The acceleration of a body travelling in a straight line is given by $a = -C_1 - C_2v^2$ where $v$ is the velocity, and $C_1, C_2$ are positive constants. Starting with an initial positive velocity $v_0$ , the distance travelled by the body before coming to rest for the first time is:
(A)	$\frac{1}{2C_2} \ln\left(1 + \frac{C_2}{C_1} v_0^2\right)$
(B)	$\frac{1}{2C_2} \ln\left(1 - \frac{C_2}{C_1} v_0^2\right)$
(C)	$\frac{1}{2C_2} \ln(C_1 + C_2 v_0^2)$
(D)	$\frac{1}{2C_2} \ln(1 + C_2 v_0^2)$

<p>Q.13</p>	<p>The three-dimensional stress-strain relationship for an isotropic material is given as</p> $\begin{Bmatrix} \sigma_{xx} \\ \sigma_{yy} \\ \sigma_{zz} \\ \tau_{yz} \\ \tau_{xz} \\ \tau_{xy} \end{Bmatrix} = \begin{bmatrix} P & Q & Q & 0 & 0 & 0 \\ Q & P & Q & 0 & 0 & 0 \\ Q & Q & P & 0 & 0 & 0 \\ 0 & 0 & 0 & R & 0 & 0 \\ 0 & 0 & 0 & 0 & R & 0 \\ 0 & 0 & 0 & 0 & 0 & R \end{bmatrix} \begin{Bmatrix} \varepsilon_{xx} \\ \varepsilon_{yy} \\ \varepsilon_{zz} \\ \gamma_{yz} \\ \gamma_{xz} \\ \gamma_{xy} \end{Bmatrix}$ <p>where, <math>P</math>, <math>Q</math> and <math>R</math> are the three elastic constants, <math>\sigma</math> and <math>\tau</math> represent normal and shear stresses and <math>\varepsilon</math> and <math>\gamma</math> represent normal and engineering shear strains. Which one of the following options is correct?</p>
(A)	$R = \frac{P - Q}{2}$
(B)	$R = \frac{Q - P}{2}$
(C)	$Q = \frac{P - R}{2}$
(D)	$Q = \frac{R - P}{2}$

Q.14

Consider the free vibration responses  $P$ ,  $Q$ ,  $R$  and  $S$  (shown in the figure) of a single degree of freedom spring-mass-damper system with the same initial conditions. For the different damping cases listed below, which one of the following options is correct?

1. Overdamped
2. Underdamped
3. Critically damped
4. Undamped

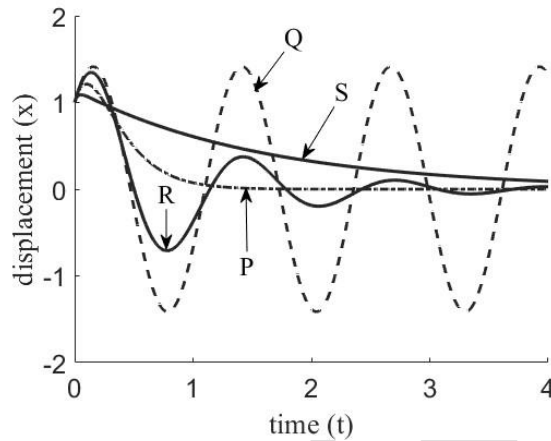

(A) P – 1, Q – 4, R – 2, S – 3

(B) P – 1, Q – 2, R – 4, S – 3

(C) P – 3, Q – 4, R – 2, S – 1

(D) P – 3, Q – 2, R – 4, S – 1

Q.15	For a single degree of freedom spring-mass-damper system subjected to harmonic forcing, the part of the motion (response) that decays due to damping is known as:
(A)	transient response
(B)	steady-state response
(C)	harmonic response
(D)	non-transient response
Q.16	For an ideal gas, the specific heat at constant pressure is 1147 J/kg K and the ratio of specific heats is equal to 1.33. What is the value of the gas constant for this gas in J/kg K?
(A)	284.6
(B)	1005
(C)	862.4
(D)	8314

Q.17	A surrogate liquid hydrocarbon fuel, approximated as $C_{10}H_{12}$ , is being burned in a land-based gas turbine combustor with dry air (79% $N_2$ and 21% $O_2$ by volume). How many moles of dry air are required for the stoichiometric combustion of the surrogate fuel with dry air at atmospheric temperature and pressure?
(A)	61.9
(B)	30.95
(C)	13
(D)	10

Q.18

In the figure shown below, various thermodynamics processes for an ideal gas are represented. Match each curve with the process that it best represents.

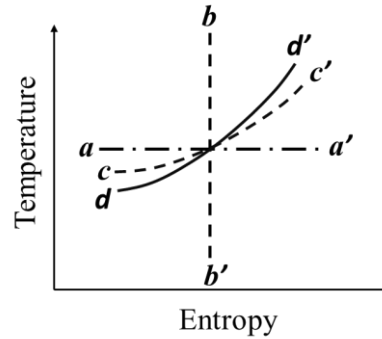

(A)

$aa'$  – Isentropic;  $bb'$  – Isothermal;  $cc'$  – Isobaric;  $dd'$  – Isochoric

(B)

$aa'$  – Isothermal;  $bb'$  – Isentropic;  $cc'$  – Isochoric;  $dd'$  – Isobaric

(C)

$aa'$  – Isothermal;  $bb'$  – Isentropic;  $cc'$  – Isobaric;  $dd'$  – Isochoric

(D)

$aa'$  – Isothermal;  $bb'$  – Isobaric;  $cc'$  – Isentropic;  $dd'$  – Isochoric

Q.19	In an airbreathing gas turbine engine, the combustor inlet temperature is 600 K. The heating value of the fuel is $43.4 \times 10^6$ J/kg. Assume $C_p$ to be 1100 J/kg K for air and burned gases, and fuel-air ratio $f \ll 1.0$ . Neglect kinetic energy at the inlet and exit of the combustor and assume 100% burner efficiency. What is the fuel-air ratio required to achieve 1300 K temperature at the combustor exit?
(A)	0.0177
(B)	0.0215
(C)	0.0127
(D)	0.0277

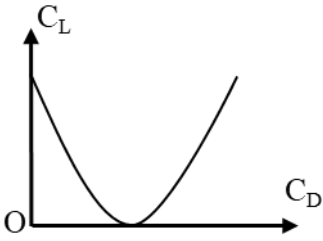
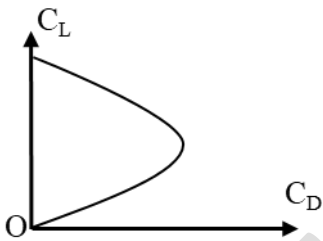
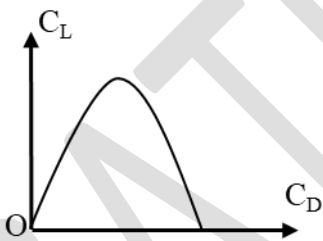
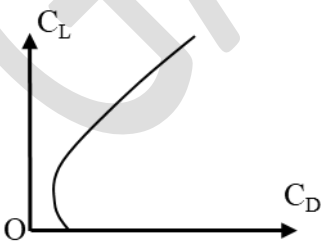
<p>Q.20</p>	<p>Which one of the following figures represents the drag polar of a general aviation aircraft?</p>
<p>(A)</p>	
<p>(B)</p>	
<p>(C)</p>	
<p>(D)</p>	

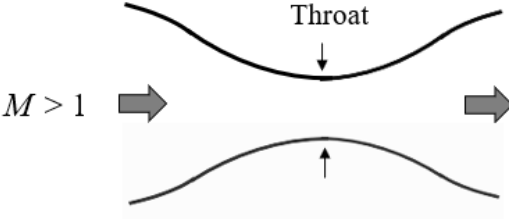

Q.21	In the context of steady, inviscid, incompressible flows, consider the superposition of a uniform flow with speed $U$ along the positive $x$ -axis (from left to right), and a source of strength $A$ located at the origin. Which one of the following statements is <b>NOT</b> true regarding the location of the stagnation point of the resulting flow?
(A)	It is located to the left of the origin
(B)	It moves closer to the origin for increasing $A$ , while $U$ is held constant
(C)	It moves closer to the origin for increasing $U$ , while $A$ is held constant
(D)	It is located along the $x$ -axis
Q.22	<p>On Day 1, an aircraft flies with a speed of <math>V_1</math> m/s at an altitude where the temperature is <math>T_1</math> K. On Day 2, the same aircraft flies with a speed of <math>\sqrt{1.2} V_1</math> m/s at an altitude where the temperature is <math>1.2 T_1</math> K. How does the Mach number <math>M_2</math> on Day 2 compare with the Mach number <math>M_1</math> on Day 1?</p> <p>Assume ideal gas behavior for air. Also assume the ratio of specific heats and molecular weight of air to be the same on both the days.</p>
(A)	$M_2 = 0.6 M_1$
(B)	$M_2 = M_1$
(C)	$M_2 = \frac{1}{\sqrt{1.2}} M_1$
(D)	$M_2 = \sqrt{1.2} M_1$

<p>Q.23</p>	<p>Consider a steady, isentropic, supersonic flow (Mach number <math>M &gt; 1</math>) entering a Convergent-Divergent (CD) duct as shown in the figure. Which one of the following options correctly describes the flow at the throat?</p>
	
<p>(A)</p>	<p>Can only be supersonic</p>
<p>(B)</p>	<p>Can only be sonic</p>
<p>(C)</p>	<p>Can either be sonic or supersonic</p>
<p>(D)</p>	<p>Can only be subsonic</p>
	<p style="text-align: center; opacity: 0.2; font-size: 48px; transform: rotate(-30deg);">GATE 2024</p>

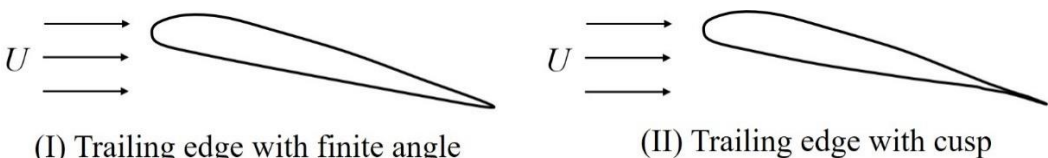
Q.24	<p>Consider steady, incompressible, inviscid flow past two airfoils shown in the figure. The coefficient of pressure at the trailing edge of the airfoil with finite angle, shown in figure (I), is <math>C_{p_I}</math> while that at the trailing edge of the airfoil with cusp, shown in figure (II), is <math>C_{p_{II}}</math>. Which one of the following options is TRUE?</p>
	 <p>(I) Trailing edge with finite angle                      (II) Trailing edge with cusp</p>
(A)	$C_{p_I} < 1, C_{p_{II}} < 1$
(B)	$C_{p_I} = 1, C_{p_{II}} = 1$
(C)	$C_{p_I} = 1, C_{p_{II}} < 1$
(D)	$C_{p_I} < 1, C_{p_{II}} = 1$
	<p style="text-align: center; font-size: 2em; opacity: 0.3; transform: rotate(-45deg);">GATE 2024</p>

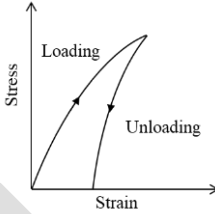
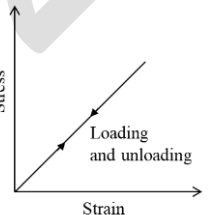
Q.25	Which of the following options is/are correct?
(A)	<p>The stress-strain graph for a nonlinear elastic material is as shown in the figure</p>  <p>The figure shows a stress-strain graph with 'Stress' on the vertical axis and 'Strain' on the horizontal axis. A curve labeled 'Loading' starts at the origin and curves upwards. A second curve labeled 'Unloading' starts from a point on the loading curve and curves back towards the origin, ending at a point on the strain axis, indicating permanent deformation.</p>
(B)	Material properties are independent of position in a homogeneous material
(C)	An isotropic material has infinitely many planes of material symmetry
(D)	<p>The stress-strain graph for a linear elastic material is</p>  <p>The figure shows a stress-strain graph with 'Stress' on the vertical axis and 'Strain' on the horizontal axis. A single straight line starts at the origin and extends upwards. The label 'Loading and unloading' is placed near the line, indicating that the loading and unloading paths are identical and follow the same linear path.</p>

Q.26	Which of the following statements is/are correct about a satellite moving in a geostationary orbit?
(A)	The orbit lies in the equatorial plane
(B)	The orbit is circular about the center of the Earth
(C)	The time period of motion is 90 minutes
(D)	The satellite is visible from all parts of the Earth
Q.27	In a conventional configuration airplane, the rudder can be used:
(A)	to overcome adverse yaw during a turning maneuver
(B)	to overcome yawing moment due to failure of one engine in a multi engine airplane
(C)	for landing the airplane in crosswind conditions
(D)	for enhancing longitudinal stability

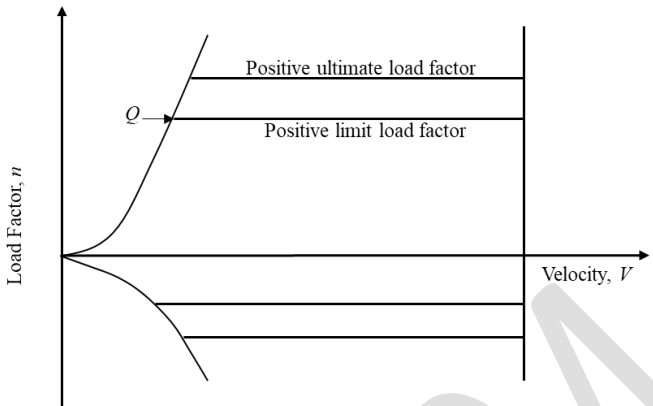
<p>Q.28</p>	<p>Which of the following statements about a general aviation aircraft, while operating at point <math>Q</math> in the <math>V</math>-<math>n</math> diagram, is/are true?</p> 
(A)	<p>The aircraft has the highest turn rate</p>
(B)	<p>The aircraft has the smallest turn radius</p>
(C)	<p>The aircraft is flying with minimum drag</p>
(D)	<p>The aircraft is operating at <math>C_{L,max}</math></p>
<p>Q.29</p>	<p>Two fair dice with numbered faces are rolled together. The faces are numbered from 1 to 6. The probability of getting odd numbers on both the dice is _____ (rounded off to 2 decimal places).</p>
<p>Q.30</p>	<p>A particle acted upon by a constant force <math>4\hat{i} + \hat{j} - 3\hat{k}</math> N is displaced from point <math>A</math> with position vector <math>\hat{i} + 2\hat{j} + 3\hat{k}</math> m to point <math>B</math> with position vector <math>5\hat{i} + 4\hat{j} + \hat{k}</math> m. The work done by this force is _____ J (answer in integer).</p>

Q.31	<p>Using Trapezoidal rule with one interval, the approximate value of the definite integral:</p> $\int_1^2 \frac{dx}{1+x^2} = \text{_____}$ <p>(rounded off to 2 decimal places).</p>
Q.32	<p>A material has Poisson's ratio <math>\nu = 0.5</math> and Young's modulus <math>E=2500</math> MPa. The percentage change in its volume when subjected to a hydrostatic stress of magnitude 10 MPa is _____ (answer in integer).</p>
Q.33	<p>An airplane experiences a net vertical ground reaction of 15000 N during landing. The weight of the airplane is 10000 N. The landing vertical load factor, defined as the ratio of inertial load to the weight of the aircraft, is _____ (rounded off to 1 decimal place).</p>
Q.34	<p>An aircraft with a turbojet engine is flying with 250 m/s speed at an altitude, where the density of air is <math>1 \text{ kg/m}^3</math>. The inlet area of the engine is <math>1 \text{ m}^2</math>. The average velocity of the exhaust gases at the exit of the nozzle, with respect to aircraft, is 550 m/s. Assume the engine exit pressure is equal to the ambient pressure and the fuel-air ratio is negligible. The uninstalled thrust produced by the engine at these conditions is _____ N (rounded off to the nearest integer).</p>
Q.35	<p>Using thin airfoil theory, the lift coefficient of a NACA 0012 airfoil placed at <math>5^\circ</math> angle of attack in a uniform flow is _____ (rounded off to 2 decimal places).</p>

## Q.36 – Q.65 Carry TWO marks Each

Q.36	<p>Given <math>y = e^{px} \sin qx</math>, where <math>p</math> and <math>q</math> are non-zero real numbers, the value of the differential expression</p> $\frac{d^2y}{dx^2} - 2p \frac{dy}{dx} + (p^2 + q^2)y$ <p>is</p>
(A)	0
(B)	1
(C)	$p^2 + q^2$
(D)	$pq$

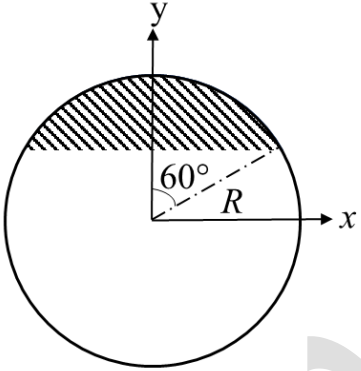

Q.37	The volume of the solid formed by a complete rotation of the shaded portion of the circle of radius $R$ about the $y$ -axis is $k\pi R^3$ . The value of $k$ is:
	
(A)	$\frac{5}{12}$
(B)	$\frac{5}{24}$
(C)	$\frac{7}{12}$
(D)	$\frac{7}{24}$

Q.38	As per the International Standard Atmosphere model, which one of the following options about density variation with increase in altitude in the isothermal layer is correct?
(A)	remains constant
(B)	increases linearly
(C)	decreases linearly
(D)	decreases exponentially
Q.39	At a point in the trajectory of an unpowered space vehicle moving about the Earth, the altitude above the mean sea level is 600 km, and the speed with reference to a coordinate system fixed to the center of mass of the Earth is 9 km/s. Assume that the Earth is a sphere with a radius 6400 km and $GM_{Earth} = 3.98 \times 10^{14} \text{ m}^3/\text{s}^2$ , where, $G$ is the universal gravitational constant and $M_{Earth}$ is mass of the Earth. The trajectory is:
(A)	Circular
(B)	Elliptic
(C)	Parabolic
(D)	Hyperbolic

Q.40	A multistage axial compressor, with overall isentropic efficiency of 0.83, is used to compress air at a stagnation temperature of 300 K through a pressure ratio of 10:1. Each stage of the compressor is similar, and the stagnation temperature rise across each compressor stage is 20 K. Assume $C_p = 1005 \text{ J/kg K}$ and $\gamma = 1.4$ for air. How many stages are there in the compressor?
(A)	17
(B)	13
(C)	19
(D)	11
Q.41	An aircraft with a turbojet engine is flying at 250 m/s. The uninstalled thrust produced by the engine is 60000 N. The heating value of the fuel is $44 \times 10^6 \text{ J/kg}$ . The engine has a thermal efficiency of 35% while burning the fuel at a rate of 3 kg/s. Assume the engine exit pressure to be equal to the ambient pressure. What is the propulsion efficiency of the engine under these conditions (in percentage)?
(A)	32.5
(B)	35.0
(C)	11.4
(D)	92.4

Q.42	Consider a flat plate, with a sharp leading edge, placed in a uniform flow of speed $U$ . The direction of the free-stream flow is aligned with the plate. Assume that the flow is steady, incompressible and laminar. The thickness of the boundary layer at a fixed stream-wise location $L$ from the leading edge of the plate is $\delta$ . Which one of the following correctly describes the variation of $\delta$ with $U$ ?
(A)	$\delta \propto U$
(B)	$\delta \propto U^{3/2}$
(C)	$\delta \propto U^{1/2}$
(D)	$\delta \propto U^{-1/2}$

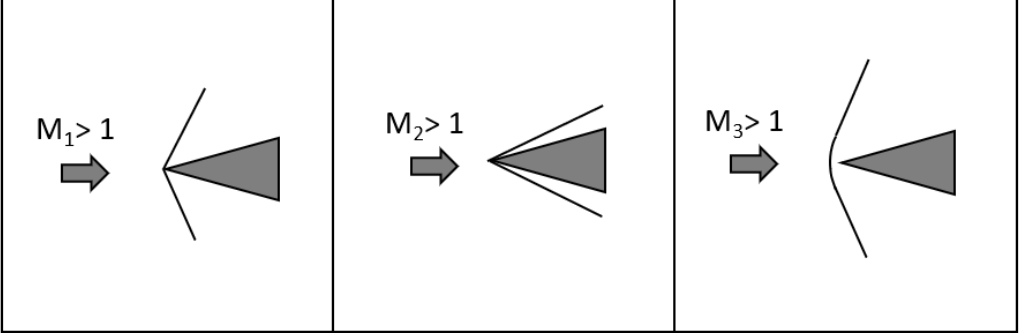
<p>Q.43</p>	<p>Shock structures for flow at three different Mach numbers over a given wedge are shown in the figure below. Assuming that only the weak shock solutions are possible for the attached oblique shocks, which one of the following options is TRUE?</p>
	 <p>The figure consists of three panels, each showing a grey wedge with a shock wave attached to its leading edge. An arrow indicates the flow direction from left to right. The first panel is labeled <math>M_1 &gt; 1</math> and shows a weak oblique shock wave. The second panel is labeled <math>M_2 &gt; 1</math> and shows a strong oblique shock wave. The third panel is labeled <math>M_3 &gt; 1</math> and shows a curved shock wave.</p>
<p>(A)</p>	<p><math>M_1 &lt; M_2 &lt; M_3</math></p>
<p>(B)</p>	<p><math>M_1 &gt; M_2 &gt; M_3</math></p>
<p>(C)</p>	<p><math>M_1 &lt; M_3 &lt; M_2</math></p>
<p>(D)</p>	<p><math>M_3 &lt; M_1 &lt; M_2</math></p>

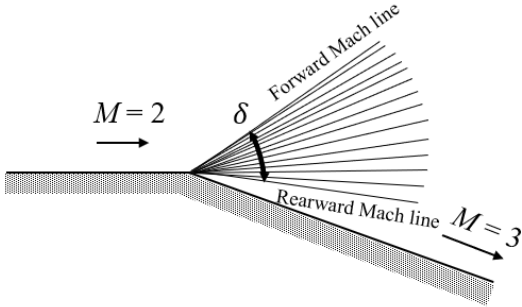
<p>Q.44</p>	<p>Air flowing at Mach number <math>M = 2</math> from left to right accelerates to <math>M = 3</math> across an expansion corner as shown in the figure. What is the value of <math>\delta</math> (the angle between the Forward and Rearward Mach lines) in degrees?</p> <p>The values of the Prandtl-Meyer functions are <math>\nu(3) = 49.76^\circ</math> and <math>\nu(2) = 26.38^\circ</math>.</p>
	
<p>(A)</p>	<p>23.38</p>
<p>(B)</p>	<p>19.47</p>
<p>(C)</p>	<p>53.38</p>
<p>(D)</p>	<p>33.91</p>

Q.45	<p>Consider the function</p> $f(x) = \begin{cases} x^2 & \text{for } x < 0 \\ x & \text{for } x \geq 0 \end{cases}$ <p>where <math>x</math> is real. Which of the following statements is/are correct?</p>
(A)	The function is continuous for all $x$
(B)	The derivative of the function is discontinuous at $x = 0$
(C)	The derivative of the function is continuous at $x = 1$
(D)	The function is discontinuous at $x = 0$

<p>Q.46</p>	<p>The figure shows plots of two yield loci for an isotropic material, where <math>\sigma_I</math> and <math>\sigma_{II}</math> are the principal stresses, and <math>\sigma_Y</math> is the yield stress in uniaxial tension. Which of the following statements is/are correct?</p>
<p>(A)</p>	<p>Criterion <i>P</i> represents the von Mises criterion</p>
<p>(B)</p>	<p>Criterion <i>Q</i> represents the Tresca criterion</p>
<p>(C)</p>	<p>Criterion <i>P</i> represents the Tresca criterion</p>
<p>(D)</p>	<p>Criterion <i>Q</i> represents the von Mises criterion</p>

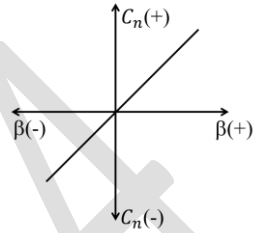

Q.47	Which of the following statements about absolute ceiling and service ceiling for a piston-propeller aircraft is/are correct?
(A)	The altitude corresponding to absolute ceiling is higher than that for service ceiling
(B)	At the absolute ceiling, the power required for cruise equals the maximum power available
(C)	The altitude corresponding to absolute ceiling is lower than that for service ceiling
(D)	At the service ceiling, the maximum rate of climb is 50 ft/min
	<p style="text-align: center; opacity: 0.3; font-size: 48px; transform: rotate(-30deg);">GATE 2024</p>

Q.48	For an airplane having directional / weathercock static stability, which of the following options is/are correct?
(A)	The airplane when disturbed in yaw, from an equilibrium state, will experience a restoring moment
(B)	The variation of yawing moment coefficient ( $C_n$ ) with sideslip angle ( $\beta$ ) for the airplane will look like 
(C)	The airplane will always tend to point into the relative wind
(D)	The airplane when disturbed in yaw will return to equilibrium state in a finite amount of time after removing the disturbance
Q.49	Which of the following statements is/are TRUE for an axial turbine?
(A)	For a fixed rotational speed, the mass flow rate increases with increase in the flow coefficient
(B)	The absolute stagnation enthalpy of the flow decreases across the nozzle row
(C)	The relative stagnation enthalpy remains unchanged through the rotor
(D)	For a fixed rotational speed, the mass flow rate remains unchanged with a change in the flow coefficient

Q.50	Which of the following statements is/are TRUE for a single stage axial compressor?
(A)	Starting from design condition and keeping the mass flow rate constant, if the blade RPM is increased, the compressor rotor may experience positive incidence flow separation (actual relative flow angle greater than the design blade angle)
(B)	Starting from design condition at the same blade RPM, if the mass flow rate is increased, the compressor rotor may experience positive incidence flow separation (actual relative flow angle greater than the design blade angle)
(C)	Keeping the mass flow rate constant, if the blade RPM is increased, the compressor may experience surge
(D)	At the same blade RPM, if the mass flow rate is increased, the compressor may experience surge
Q.51	Consider the matrix $A = \begin{bmatrix} 5 & -4 \\ k & -1 \end{bmatrix}$ , where $k$ is a constant. If the determinant of $A$ is 3, then the ratio of the largest eigenvalue of $A$ to the constant $k$ is _____ (rounded off to 1 decimal place).

Q.52

The state of stress at a point is caused by two separate loading cases. One of them produces a pure uniaxial tension along the  $x'$  direction, and other one produces a pure uniaxial compression along the  $y'$  direction, as shown in the figure. The sum of maximum and minimum principal stresses for the resultant state of stress caused by both loads acting simultaneously is \_\_\_\_\_  $\text{N/mm}^2$  (rounded off to 1 decimal place).

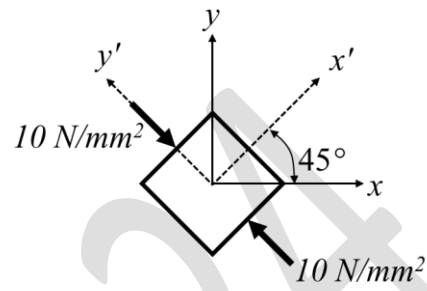
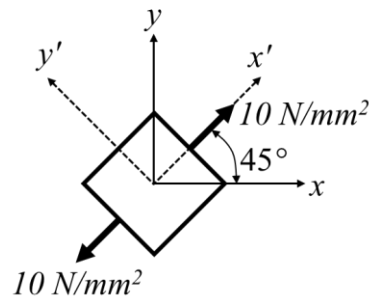

Q.53

In the figure shown below, the magnitude of internal force in member BC is \_\_\_\_\_ N (rounded off to 1 decimal place).

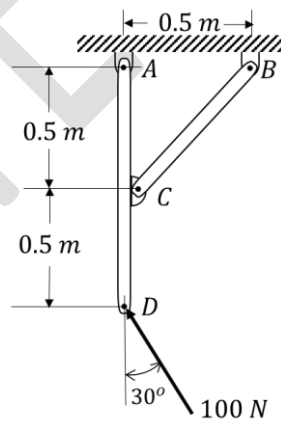

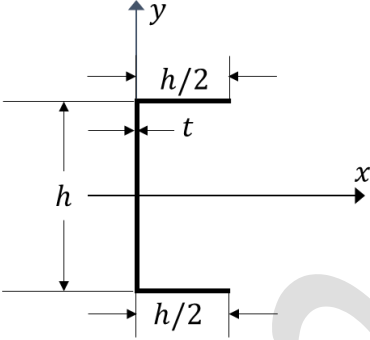
<p>Q.54</p>	<p>The cross section of a thin-walled beam with uniform wall thickness <math>t</math>, shown in the figure, is subjected to a bending moment <math>M_x = 10 \text{ Nm}</math>. If <math>h = 1 \text{ m}</math> and <math>t = 0.001 \text{ m}</math>, the magnitude of maximum normal stress in the cross section is _____ <math>\text{N/m}^2</math> (answer in integer).</p>
	
<p>Q.55</p>	<p>The equations of motion for a two degrees of freedom undamped spring-mass system are:</p> $m\ddot{x}_1 + 2kx_1 - kx_2 = 0$ $m\ddot{x}_2 - kx_1 + 2kx_2 = 0$ <p>where <math>m</math> and <math>k</math> represent mass and stiffness respectively, in corresponding SI units, and <math>x_1</math> and <math>x_2</math> are the degrees of freedom. The larger of the two natural frequencies is given by: <math>\omega = \alpha \sqrt{\frac{k}{m}}</math> rad/s. The value of <math>\alpha</math> is _____ (rounded off to 2 decimal places).</p>
<p>Q.56</p>	<p>Consider the plane strain field given by</p> $\varepsilon_{xx} = 10xy^2, \quad \varepsilon_{yy} = -5x^2y \quad \text{and} \quad \gamma_{xy} = Axy(2x - y)$ <p>where, <math>A</math> is a constant and <math>\gamma_{xy}</math> is the engineering shear strain. The value of the constant <math>A</math> for the strain field to be compatible is _____ (rounded off to 1 decimal place).</p>

Q.57	A chemical rocket with an ideally expanded flow through the nozzle produces $5 \times 10^6$ N thrust at sea level. The specific impulse of the rocket is 200 s and acceleration due to gravity at the sea level is $9.8 \text{ m/s}^2$ . The propellant mass flow rate out of the rocket nozzle is _____ kg/s ( <i>rounded off to the nearest integer</i> ).
Q.58	A centrifugal compressor is designed to operate with air. At the leading edge of the tip of the inducer (eye of the impeller), the blade angle is $45^\circ$ , and the relative Mach number is 1.0. The stagnation temperature of the incoming air is 300 K. Consider $\gamma = 1.4$ . Neglect pre-whirl and slip. The inducer tip speed is _____ m/s ( <i>rounded off to the nearest integer</i> ).
Q.59	Consider the following Fanno flow problem: Flow enters a constant area duct at a temperature of 273 K and a Mach number 0.2 and eventually reaches sonic condition (Mach number =1) due to friction. Assume $\gamma = 1.4$ . The static temperature at the location where sonic condition is reached is _____ K ( <i>rounded off to 2 decimal places</i> ).
Q.60	Consider an artificial satellite moving around the Moon in an elliptic orbit. The altitude of the satellite from the Moon's surface at the perigee is 25 km and that at the apogee is 134 km. Assume the Moon to be spherical with a radius of 1737 km. The trajectory is considered with reference to a coordinate system fixed to the center of mass of the Moon. The ratio of the speed of the satellite at the perigee to that at the apogee is _____ ( <i>rounded off to 2 decimal places</i> ).
Q.61	For an aircraft moving at 4 km altitude above mean sea level at a Mach number of 0.2, the ratio of equivalent air speed to true air speed is _____ ( <i>rounded off to 2 decimal places</i> ).  The density of air at mean sea level is $1.225 \text{ kg/m}^3$ and at 4 km altitude is $0.819 \text{ kg/m}^3$ .

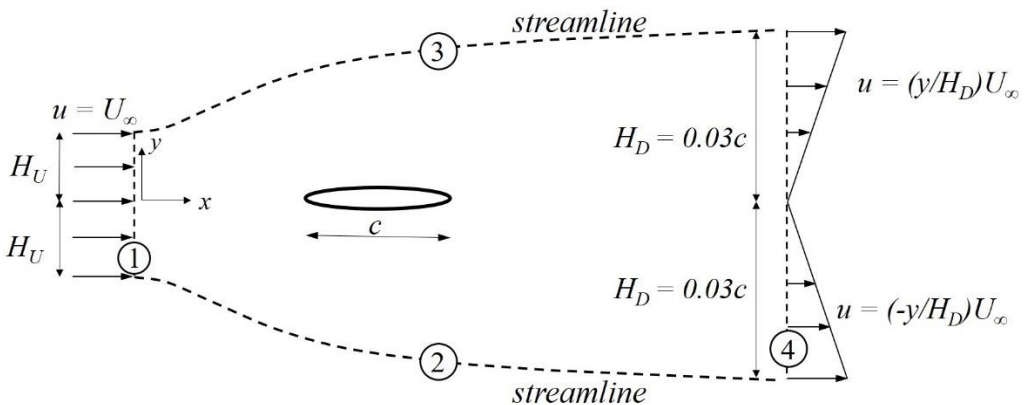
<p>Q.62</p>	<p>For a general aviation airplane, one of the complex conjugate pair of eigenvalues for longitudinal dynamics is given by <math>-0.039 \pm 0.0567 i</math> (in SI units). If the system is disturbed to excite only this mode, the time taken for the amplitude of response to become half in magnitude is _____ s (rounded off to 1 decimal place).</p>
<p>Q.63</p>	<p>The figure (not to scale) shows a control volume to estimate the forces on the airfoil with elliptic cross-section. Surfaces 2 and 3 are streamlines. Velocity profiles are measured at the upstream end (surface 1) and at the downstream end (surface 4) of the control volume. The drag coefficient for the airfoil is defined as <math>C_d = \frac{D}{\frac{1}{2} \rho U_\infty^2 c}</math>, where <math>D</math> is the drag force on the airfoil per unit span and <math>\rho</math> is the density of the air. The static pressure, <math>p_\infty</math>, is constant over the entire surface of the control volume. Assuming the flow to be incompressible, two-dimensional and steady, the <math>C_d</math> for the airfoil is _____ (rounded off to 3 decimal places).</p>
	
<p>Q.64</p>	<p>An airplane of mass 1000 kg is in a steady level flight with a speed of 50 m/s. The wing has an elliptic planform with a span of 20 m and planform area 31.4 m<sup>2</sup>. Assuming the density of air at that altitude to be 1 kg/m<sup>3</sup> and acceleration due to gravity to be 10 m/s<sup>2</sup>, the induced drag on the wing is _____ N (rounded off to 1 decimal place).</p>

Q.65

It is desired to estimate the aerodynamic drag,  $D$ , on a car traveling at a speed of 30 m/s. A one-third scale model of the car is tested in a wind-tunnel following the principles of dynamic similarity. The drag on the scaled model is measured to be  $D_m$ . The ratio  $D/D_m$  is \_\_\_\_\_ (rounded off to 1 decimal place).

GATE 2024





GRADUATE APTITUDE TEST IN ENGINEERING 2024

अभियांत्रिकी स्नातक अभिक्षमता परीक्षा २०२४

ORGANISING INSTITUTE: INDIAN INSTITUTE OF SCIENCE, BENGALURU



## Aerospace Engineering (AE) Master Answer Key

Q. No.	Session	Question Type	Section	Key/Range	Mark
1	5	MCQ	GA	A	1
2	5	MCQ	GA	D	1
3	5	MCQ	GA	A	1
4	5	MCQ	GA	C	1
5	5	MCQ	GA	A	1
6	5	MCQ	GA	C	2
7	5	MCQ	GA	A	2
8	5	MCQ	GA	C	2
9	5	MCQ	GA	A	2
10	5	MCQ	GA	A	2
11	5	MCQ	AE	A	1
12	5	MCQ	AE	A	1
13	5	MCQ	AE	A	1
14	5	MCQ	AE	C	1
15	5	MCQ	AE	A	1
16	5	MCQ	AE	A	1
17	5	MCQ	AE	A	1
18	5	MCQ	AE	C	1
19	5	MCQ	AE	A	1
20	5	MCQ	AE	D	1
21	5	MCQ	AE	B	1
22	5	MCQ	AE	B	1
23	5	MCQ	AE	C	1
24	5	MCQ	AE	C	1
25	5	MSQ	AE	B;C;D	1
26	5	MSQ	AE	A;B	1
27	5	MSQ	AE	A;B;C	1
28	5	MSQ	AE	A;B;D	1

29	5	NAT	AE	0.24 to 0.26	1
30	5	NAT	AE	24 to 24	1
31	5	NAT	AE	0.35 to 0.35	1
32	5	NAT	AE	0 to 0	1
33	5	NAT	AE	1.5 to 1.5	1
34	5	NAT	AE	75000 to 75000	1
35	5	NAT	AE	0.54 to 0.56	1
36	5	MCQ	AE	A	2
37	5	MCQ	AE	B	2
38	5	MCQ	AE	D	2
39	5	MCQ	AE	B	2
40	5	MCQ	AE	A	2
41	5	MCQ	AE	A	2
42	5	MCQ	AE	D	2
43	5	MCQ	AE	D	2
44	5	MCQ	AE	D	2
45	5	MSQ	AE	A;B;C	2
46	5	MSQ	AE	A;B	2
47	5	MSQ	AE	A;B	2
48	5	MSQ	AE	A;B;C	2
49	5	MSQ	AE	A;C	2
50	5	MSQ	AE	A;C	2
51	5	NAT	AE	1.4 to 1.6	2
52	5	NAT	AE	0 to 0	2
53	5	NAT	AE	141.0 to 141.5	2
54	5	NAT	AE	14900 to 15100	2
55	5	NAT	AE	1.72 to 1.74	2
56	5	NAT	AE	4.9 to 5.1	2
57	5	NAT	AE	2500 to 2600	2
58	5	NAT	AE	230 to 240	2
59	5	NAT	AE	227.0 to 231.0	2
60	5	NAT	AE	1.05 to 1.07	2
61	5	NAT	AE	0.80 to 0.84	2
62	5	NAT	AE	17.7 to 17.9	2
63	5	NAT	AE	0.018 to 0.022	2
64	5	NAT	AE	63.0 to 64.5	2
65	5	NAT	AE	1.0 to 1.0	2